

PARTS LIST				
ITEM	QTY	PART NUMBER	MATERIAL	DESCRIPTION
1	2	SIDE PLATE SUB-ASSEMBLY		
1.1	1	SIDE PLATE	MILD STEEL	
1.2	1	GUIDE	CAST IRON	
1.3	2	RIVET	STANDARD	BUTTON HEAD, Ø10 X 60 LONG
2	1	AXLE	COLD ROLLED STEEL	
3	1	HOOK	MILD STEEL	10 THICK
4	44	ROLLER BEARING	COLD ROLLED STEEL	Ø10 X 38 LONG
5	4	WHEEL	CAST IRON	
6	4	WHEEL AXLE	COLD ROLLED STEEL	
7	12	ADJUSTING WASHER	STANDARD	Ø26ID X Ø44OD X 4 THICK
8	4	WASHER	STANDARD	Ø26ID X Ø65OD X 3 THICK
9	4	LOCKNUT	STANDARD	M16 x 2 (PREVAILING TORQUE INSERT-TYPE)
10	6	COTTER PIN	STANDARD	Ø6 X 40 LONG



TROLLEY  
SCALE 1 / 2

METRIC

**GENERAL NOTES:**  
TROLLEY ASSEMBLY TO BE MOUNTED TO S200 X 34 BEAM

**LEGEND:**

- ∅ DIAMETER
- R RADIUS
- ° DEGREES

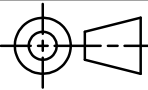
 DIGITAL DESIGN GRAPHICS TECHNOLOGY WWW.DDGT.NET	 NICHOLAS RODRIGUEZ DRAFTING AND DESIGN (707) 561-2948 RODRIGUEZNICHOLAS989@GMAIL.COM WWW.DDGT.NET/STUDENTPAGES/NRODRIGUEZ	 TOLERANCES UNLESS SPECIFIED: MILLIMETER: WHOLE NUMBER = ±.5 X = ±.25 XX = ±.12 ANGLES ±1 DEGREE SURFACES $\sqrt{\quad}$	COURSE: DDGT120
			INVENTOR DRAWING NAME TROLLEY
			FIG #: 14-83
			DRAFTER: N. RODRIGUEZ
			DATE: 12/3/2020
			SCALE: AS NOTED
			PAGE #: 1 OF 6

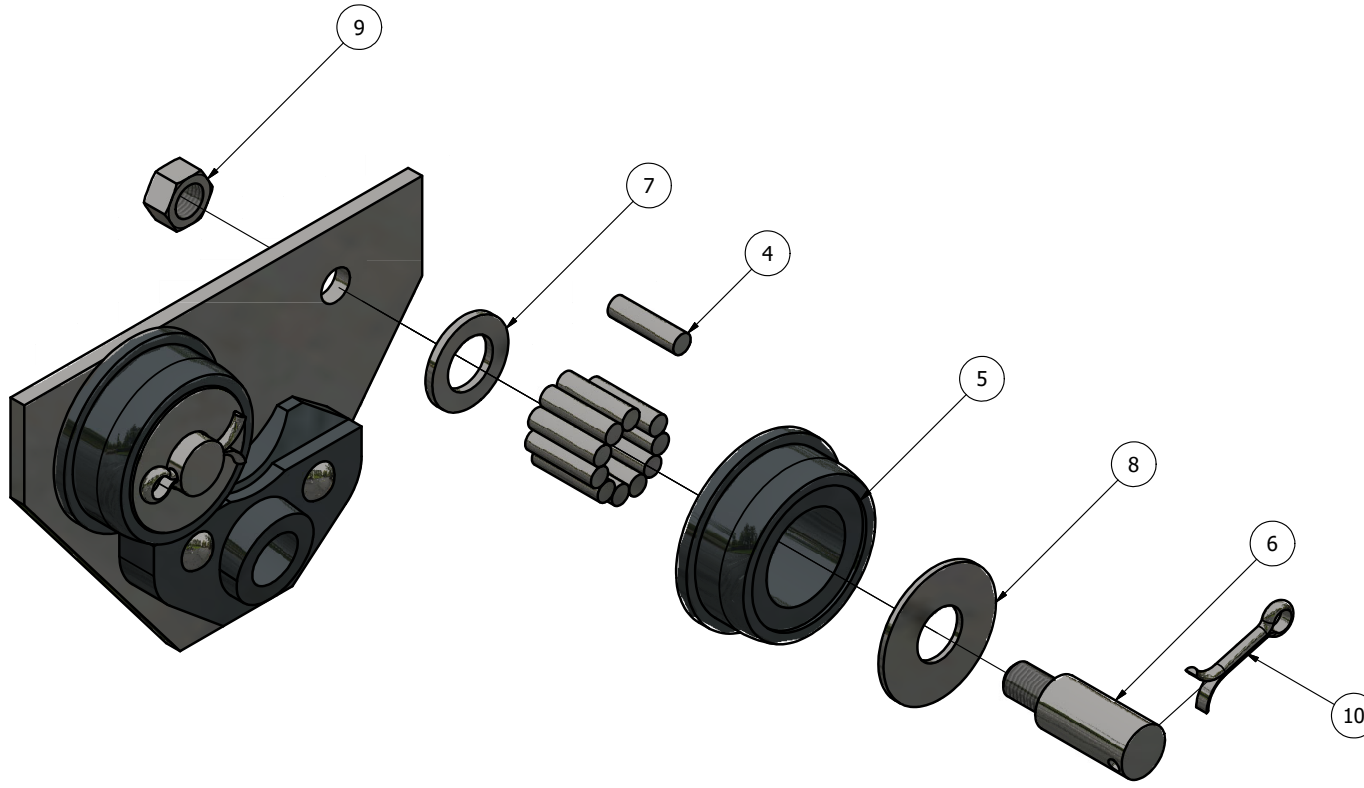

SIDE PLATE EXPLODED ASSEMBLY  
SCALE 1 / 2

PARTS LIST		
ITEM	QTY	PART NUMBER
1	2	SIDE PLATE SUB-ASSEMBLY
1.1	1	SIDE PLATE
1.2	1	GUIDE
1.3	2	RIVET
2	1	AXLE
3	1	HOOK
4	44	ROLLER BEARING
5	4	WHEEL
6	4	WHEEL AXLE
7	12	ADJUSTING WASHER
8	4	WASHER
9	4	LOCKNUT
10	6	COTTER PIN

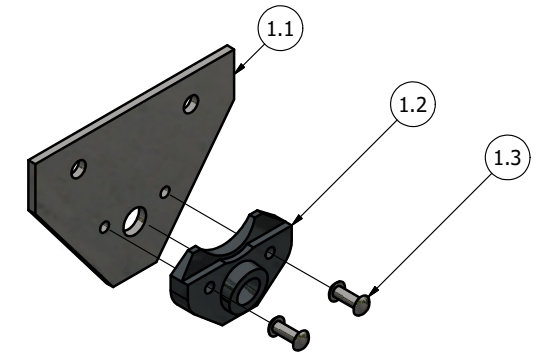

SIDE PLATE EXPLODED SUB-ASSEMBLY  
SCALE 1 / 4

**DDGT**

DIGITAL DESIGN  
GRAPHICS  
TECHNOLOGY

WWW.DDGT.NET



NICHOLAS RODRIGUEZ  
DRAFTING AND DESIGN

(707)-561-2948  
RODRIGUEZNICHOLAS989@GMAIL.COM  
WWW.DDGT.NET/STUDENTPAGES/NRODRIGUEZ

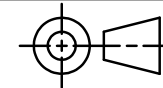

TOLERANCES UNLESS SPECIFIED:  
MILLIMETER:  
WHOLE NUMBER = ±.5  
X = ±.25  
XX = ±.12  
ANGLES ±1 DEGREE  
SURFACES  $\checkmark$  32

COURSE: DDGT120

INVENTOR DRAWING NAME  
TROLLEY

FIG #: 14-83

DRAFTER: N. RODRIGUEZ

DATE: 12/3/2020

SCALE: AS NOTED

PAGE #: 2 OF 6

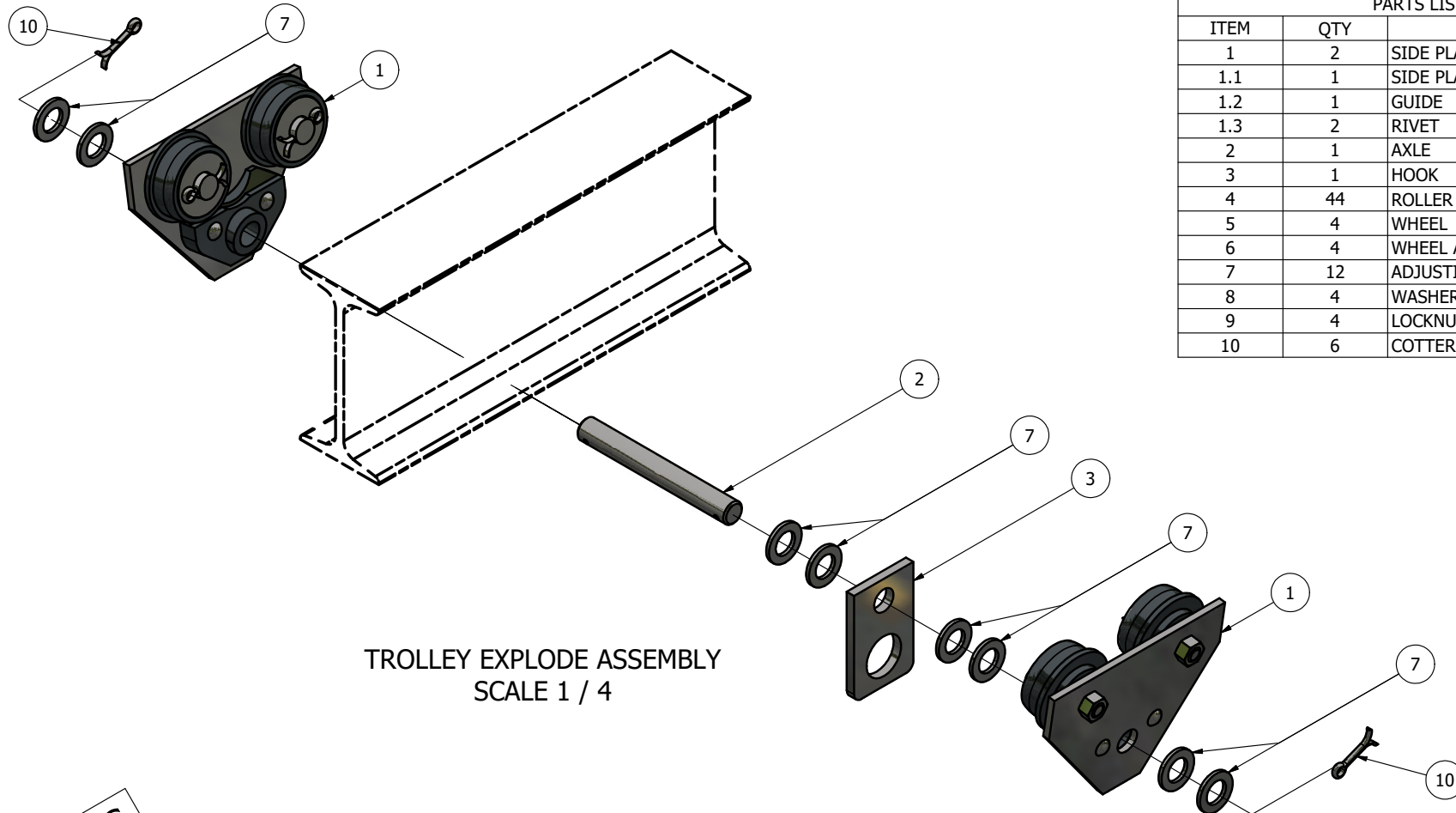



PARTS LIST		
ITEM	QTY	PART NUMBER
1	2	SIDE PLATE SUB-ASSEMBLY
1.1	1	SIDE PLATE
1.2	1	GUIDE
1.3	2	RIVET
2	1	AXLE
3	1	HOOK
4	44	ROLLER BEARING
5	4	WHEEL
6	4	WHEEL AXLE
7	12	ADJUSTING WASHER
8	4	WASHER
9	4	LOCKNUT
10	6	COTTER PIN

TROLLEY EXPLODE ASSEMBLY  
SCALE 1 / 4

**LEGEND:**

- ∅ DIAMETER
- R RADIUS
- ° DEGREES

METRIC

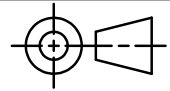
 <b>DIGITAL DESIGN GRAPHICS TECHNOLOGY</b> <a href="http://WWW.DDGT.NET">WWW.DDGT.NET</a>	 <b>NICHOLAS RODRIGUEZ</b> DRAFTING AND DESIGN (707)-561-2948 <a href="mailto:RODRIGUEZNICHOLAS989@gmail.com">RODRIGUEZNICHOLAS989@gmail.com</a> <a href="http://WWW.DDGT.NET/STUDENTPAGES/NRODRIGUEZ">WWW.DDGT.NET/STUDENTPAGES/NRODRIGUEZ</a>	 TOLERANCES UNLESS SPECIFIED: MILLIMETER: WHOLE NUMBER = ±.5 X = ±.25 XX = ±.12 ANGLES ±1 DEGREE SURFACES $\checkmark$	COURSE: <b>DDGT120</b>
			INVENTOR DRAWING NAME <b>TROLLEY</b>
			FIG #: <b>14-83</b>
			DRAFTER: <b>N. RODRIGUEZ</b>
			DATE: <b>12/3/2020</b>
			SCALE: <b>AS NOTED</b>
			PAGE #: <b>3 OF 6</b>

PARTS LIST		
ITEM	QTY	PART NUMBER
1.1	2	SIDE PLATE

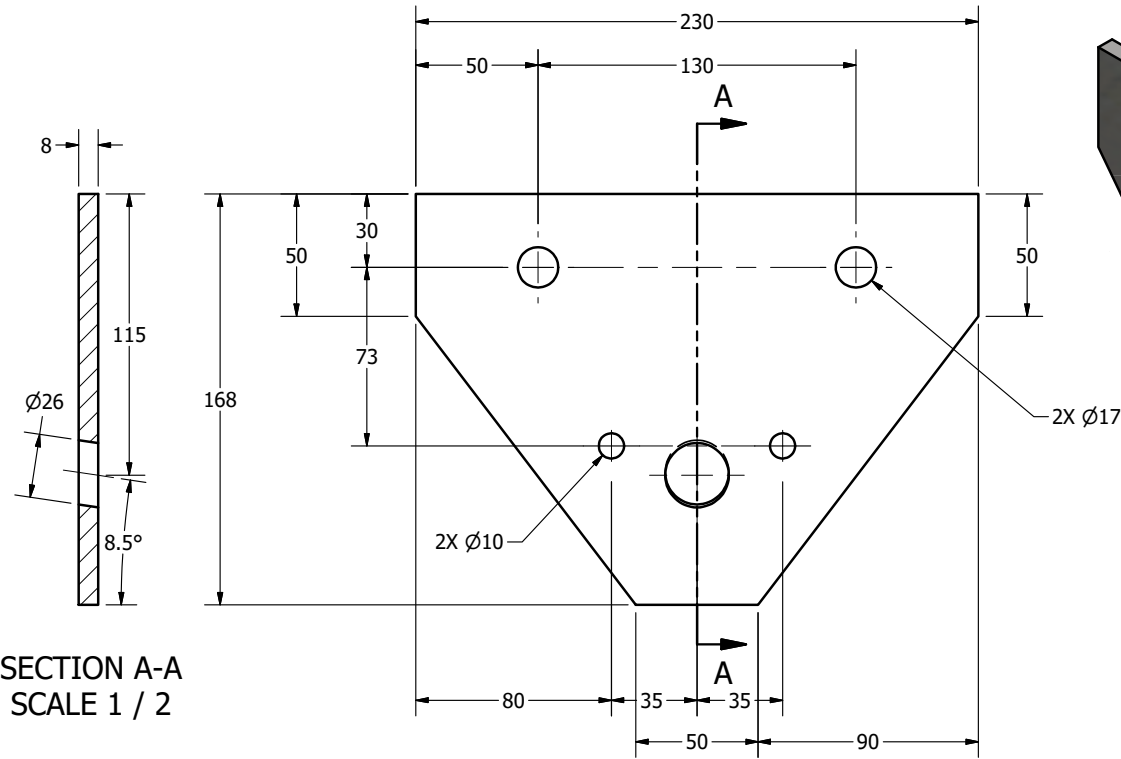

SECTION A-A  
SCALE 1 / 2

SIDE PLATE  
SCALE 1 / 2

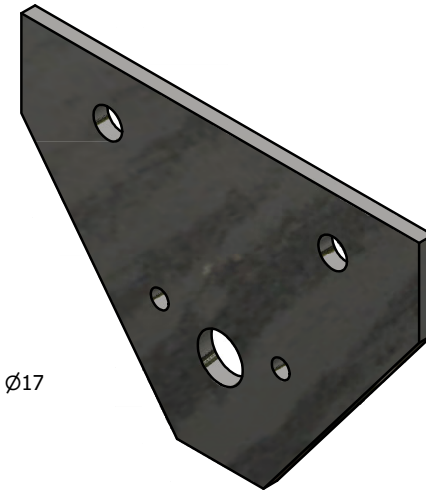

**LEGEND:**

- ∅ DIAMETER
- R RADIUS
- ° DEGREES

METRIC

**DDGT**

DIGITAL DESIGN  
GRAPHICS  
TECHNOLOGY

WWW.DDGT.NET



NICHOLAS RODRIGUEZ  
DRAFTING AND DESIGN

(707)-561-2948  
RODRIGUEZNICHOLAS989@GMAIL.COM  
WWW.DDGT.NET/STUDENTPAGES/NRODRIGUEZ

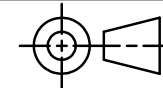

TOLERANCES UNLESS SPECIFIED:  
MILLIMETER:  
WHOLE NUMBER = ±.5  
X = ±.25  
XX = ±.12  
ANGLES ±1 DEGREE  
SURFACES 32 ✓

COURSE: DDGT120

INVENTOR DRAWING NAME  
TROLLEY

FIG #: 14-83

DRAFTER: N. RODRIGUEZ

DATE: 12/3/2020

SCALE: AS NOTED

PAGE #: 4 OF 6



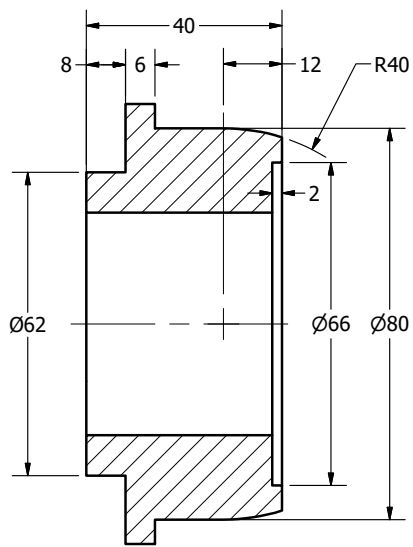

SECTION C-C  
SCALE 1 : 1

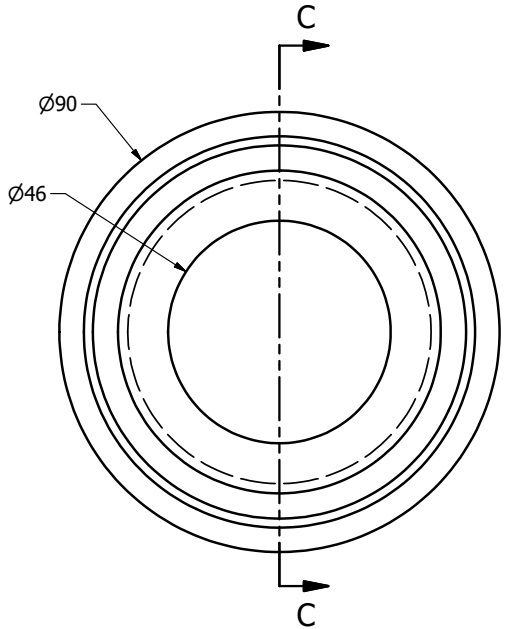

WHEEL  
SCALE 1 : 1

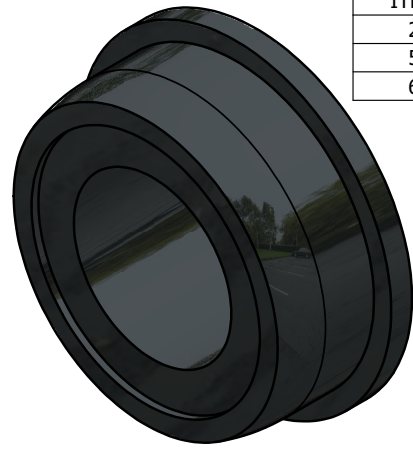

PARTS LIST		
ITEM	QTY	PART NUMBER
2	1	AXLE
5	4	WHEEL
6	4	WHEEL AXLE

**LEGEND:**

- ∅ DIAMETER
- R RADIUS
- ° DEGREES

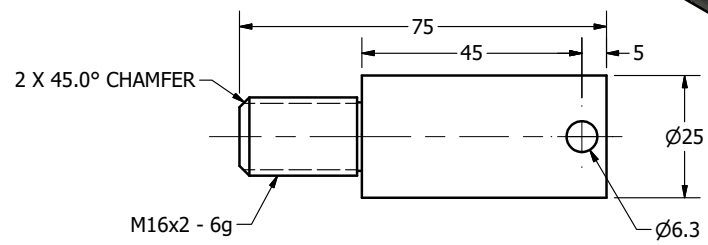
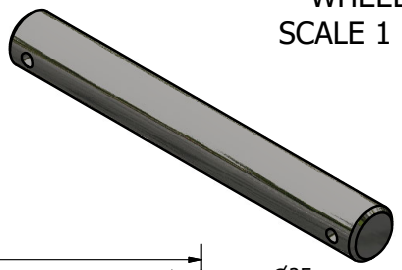

WHEEL AXLE  
SCALE 1 : 1

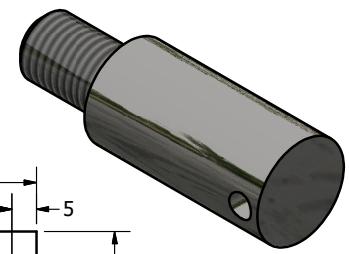

METRIC

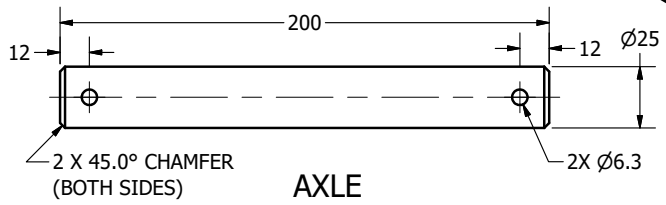

AXLE  
SCALE 1 / 2



DIGITAL DESIGN  
GRAPHICS  
TECHNOLOGY

WWW.DDGT.NET



NICHOLAS RODRIGUEZ  
DRAFTING AND DESIGN

(707)-561-2948  
RODRIGUEZNICHOLAS989@GMAIL.COM  
WWW.DDGT.NET/STUDENTPAGES/NRODRIGUEZ

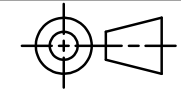

TOLERANCES UNLESS SPECIFIED:  
MILLIMETER:  
WHOLE NUMBER = ±.5  
X = ±.25  
XX = ±.12  
ANGLES ±1 DEGREE  
SURFACES 32 ✓

COURSE: DDGT120

INVENTOR DRAWING NAME  
TROLLEY

FIG #: 14-83

DRAFTER: N. RODRIGUEZ

DATE: 12/3/2020

SCALE: AS NOTED

PAGE #: 6 OF 6